

Key Highlights:

- Type: 100GBASE-LR4 & OTU4 & 128GFC QSFP28 20 km
- Compatibility: Multi-Vendor MSA Compatible
- Tx/Rx Wavelength: 1295.56, 1300.05, 1304.58, 1309.14 nm
- Laser: EML Cooled LAN WDM TOSA
- Fiber Type: Single-Mode Fiber (SMF)
- Connectors: Double LC
- Optical Budget: 10 dB
- Max. Distance: 20 km
- Data Rate: 103.125 - 112.2 Gbps
- FEC Forward Error Correction: Supported
- DDM/DOM: Supported
- Power Consumption: $\leq 3.5W$
- Temperature: Industrial -45° - $+85^{\circ}C$



Optical Transceiver : 100G-QSFP28-20I

Product Description:

100G-QSFP28-20I is Multi-Vendor MSA Compatible 100GBASE-LR4 QSFP28 (Quad Small Form-Factor Pluggable 28) Transceiver, operating over pair of single-mode optical fiber with four independent optical communication lanes, separated from each other using LAN WDM technology. Module has minimum guaranteed optical budget of 9 dB, which in most cases is enough to reach 20 km distance using single-mode cable. However, distance is just indicative parameter calculated for comfort of identification. Eventually we calculate distance taking in account minimal optical budget and average attenuation of optical cabling in industry. 100G-QSFP28-20I uses cooled 4x28Gb/s LAN WDM TOSA (1295.56, 1300.05, 1304.58, 1309.14nm) laser transmitters and 4x28Gb/s PIN ROSA receivers. Module support DDM/DOM optical diagnostics, which provide diagnostic information about the present operating conditions. Additionally module supports FEC (Forward Error Correction) function which will help receiving side detect and correct bit errors and improve the overall quality of the link. 100G-QSFP28-20I operates in Industrial -45° - $+85^{\circ}C$ temperature range and has double LC connectors.



100GBASE-LR4 QSFP28 support up to 103.125-112.2 Gbps data rate and such applications as 100G Ethernet (103.125Gbps), Optical Transport Network OTU4 4I1-9D1F (112 Gbps) and 128G Fiber Channel (112.2 Gbps). 100G-QSFP28-20I optical transceiver is multi-purpose module used in number of different places in today's networking environment. Most popular applications are Internet Service Provider (ISP) Fiber to the Home Aggregation and Backbone, Mobile Operator Core Networks and Mobile Backhaul and Data Center networking site interconnections.

Transceiver is CE/RoHS certified and it is Compliant with product safety standards. 100G-QSFP28-20I Transceiver is fully compliant to QSFP28 Multi Source Agreement (MSA), IEEE 802.3ba 100GBASE-LR4 and IEEE 802.3bm, Optical Transport Network OTU4 4I1-9D1F and 128G Generation 6 Fiber Channel standards. Consequently compliance to above standards guarantees that module is compatible and works with majority of networking equipment, where is not implemented special algorithm for protection against third party modules. However – our technical team has accumulated deep expertise in custom-encoded firmwares for 100GBASE-LR4 QSFP28 transceiver in order to make it work in almost any brand equipment. We will be glad to know your requirements.

Product Specification:

General parameter	Value
Media Type:	Single-Mode Fiber (SMF)
Connectors:	Double LC
TX Wavelength:	295.56, 1300.05, 1304.58, 1309.14 nm
RX Wavelength:	1295.56, 1300.05, 1304.58, 1309.14 nm
Minimum Optical Budget:	9 dB
Maximum Distance:	20 km
Supported Data Rate:	103.125 - 112.2 Gbps
Data Rate, each Lane up to:	28.05Gbps
Supported Applications:	100G Ethernet (103.125Gbps), OTU4 4I1-9D1F (112 Gbps), 128GFC (112.2 Gbps)
Digital Diagnostic Monitoring (DDM):	Supported
Optical Clock And Data Recovery (CDR):	Supported
Forward Error Correction (FEC):	Supported
Operating Temperature Range:	Industrial -45° - +85°C



Product Specification:

General parameter	Value
Storage Temperature Range:	- 40° to 85°C
Relative Humidity (Non-Condensation):	0 to 85%
Power Consumption:	≤ 3.5W
Power Supply Voltage Typical:	+ 3.3V
Power Supply Voltage Range:	- 3.135 to 3.465V
Chipset:	Macom, Sumitomo, Samtech, Oclaro, Avago, II-IV
Compliance:	QSFP28 MSA, IEEE 802.3ba 100GBASE-LR4, IEEE 802.3bm, OTN OTU4 4 1-9D1F, 128GFC Gen 6, SFF-8636, SFF-8665, CE, RoHS-6, Class 1 FDA, IEC60825-1 Laser Safety Compliant

Transmitter Parameters:	Value
Transmitter Type:	EML LAN WDM TOSA
Tx Wavelength Bandwidth:	4 LAN WDM Separated 1310 nm Lanes (15.66 nm 1294.53 – 1310.19nm) (L0 Tx center 1295.56nm, L1 Tx center 1300.05nm, L2 Tx center 1304.58nm, L3 Tx center 1309.14nm)
Total Average Launch Power (Min)	-2 dBm
Total Average Launch Power (Max)	8.3 dBm
Average Launch Power (Min) Each Lane:	-1 dBm
Average Launch Power (Max) Each Lane:	4.5 dBm
Optical Modulation Amplitude OMA (Min) Each Lane:	-2 dBm
Optical Modulation Amplitude OMA (Max) Each Lane:	4.5 dBm
Difference in Launch Power between any Two Lanes OMA (Max):	6.5 dBm
Launch Power in OMA minus TDEC (Min) Each Lane:	-1.8 dBm
TDP Each Lane:	2.2 dB
Extinction Ratio (Min):	4 dB



Transmitter Parameters:	Value
Optical Return Loss Tolerance (Max):	20 dB
Relative Intensity Noise:	- 128 dB/HZ
Side-mode Suppression Ratio:	30 dB
Average Launch Power OFF Transmitter (Max) Each Lane:	- 30 dBm
Receiver Parameters:	Value
Receiver Type:	PIN ROSA
Rx Wavelength Bandwidth:	4 LAN WDM Separated 1310 nm Lanes (15.66 nm 1294.53 – 1310.19nm) (L0 Tx center 1295.56nm, L1 Tx center 1300.05nm, L2 Tx center 1304.58nm, L3 Tx center 1309.14nm)
Average Receiver Sensitivity (Min) Each Lane:	-11 dBm
Average Receiver Sensitivity (Max) Each Lane:	0 dBm
Receiver Overload:	3.3 dBm
Receiver Reflectance (Max) Each Lane:	- 26 dB
RSSI Accuracy (Min):	- 2 dB
RSSI Accuracy (Max):	2 dB
Receive Power OMA (Max) Each Lane:	3.5 dBm
LOS Assert (Min):	-25 dBm
LOS De-assert (Max):	-15 dBm
LOS Hysteresis (Min):	0.5 dB



Transmitter Parameters:	Value
Optical Return Loss Tolerance (Max):	20 dB
Relative Intensity Noise:	- 128 dB/HZ
Side-mode Suppression Ratio:	30 dB
Average Launch Power OFF Transmitter (Max) Each Lane:	- 30 dBm
Receiver Parameters:	Value
Receiver Type:	PIN ROSA
Rx Wavelength Bandwidth:	4 LAN WDM Separated 1310 nm Lanes (15.66 nm 1294.53 – 1310.19nm) (L0 Tx center 1295.56nm, L1 Tx center 1300.05nm, L2 Tx center 1304.58nm, L3 Tx center 1309.14nm)
Average Receiver Sensitivity (Min) Each Lane:	-11 dBm
Average Receiver Sensitivity (Max) Each Lane:	0 dBm
Receiver Overload:	3.3 dBm
Receiver Reflectance (Max) Each Lane:	- 26 dB
RSSI Accuracy (Min):	- 2 dB
RSSI Accuracy (Max):	2 dB
Receive Power OMA (Max) Each Lane:	3.5 dBm
LOS Assert (Min):	-25 dBm
LOS De-assert (Max):	-15 dBm
LOS Hysteresis (Min):	0.5 dB



Mechanical Dimensions:

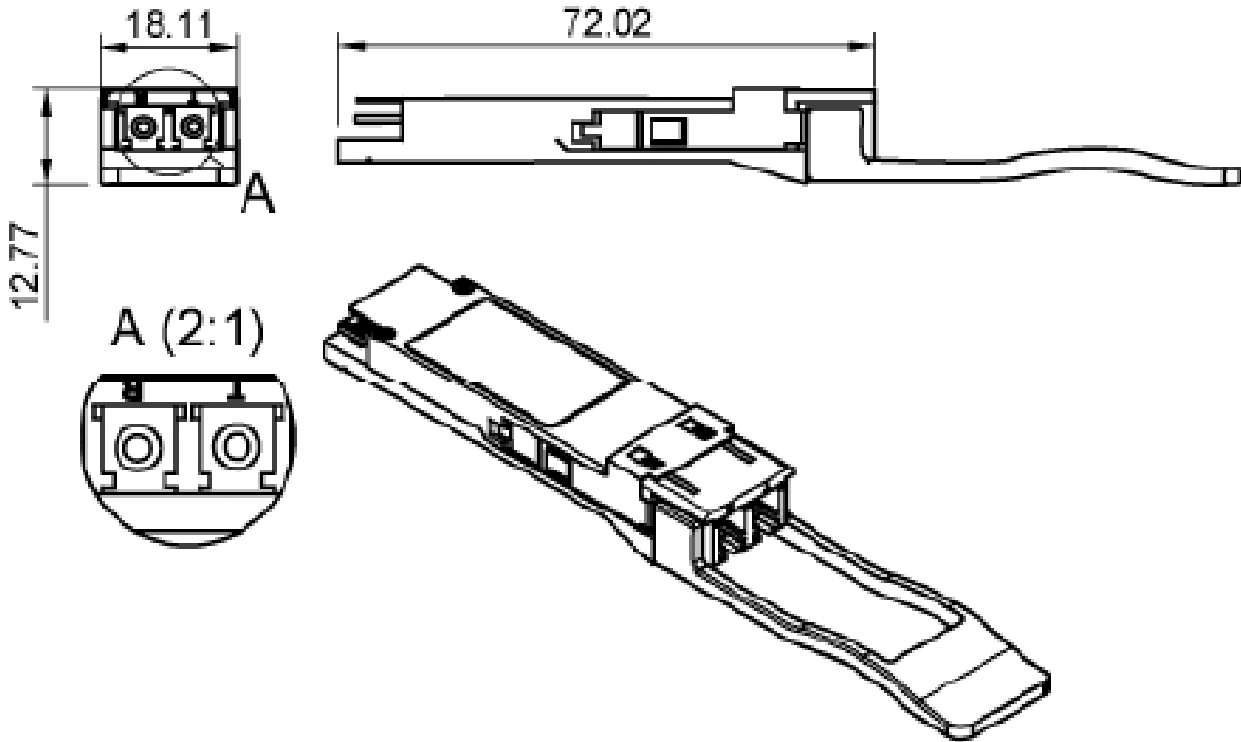

Compatibility:

EDGE Optical transceivers can be provided with custom-encoded firmware, in order to provide compatibility with more than 100 vendor brands in data and telecom communications industry:

MS - General MSA**AD** - ADVA**AE** - Advantech**AL** - Alcatel (Nokia)**AT** - Allied Telesis**AR** - Arista**AS** - Arris**AV** - Avaya**BC** - Barracuda**BR** - Broadcom**QL** - Cavium (Qlogic)**CR** - Ceragon**CP** - Checkpoint**CH** - Chelsio**CN** - Ciena**CI** - Cisco**LI** - Cisco (Linksys)**CE** - Comnet**CO** - Coriant**DH** - Dahua**DC** - DCN**DL** - Dell & Force10**DK** - D-Link**DZ** - DZS(Dasan-Zhone)**EI** - ECI**EC** - EdgeCore**EW** - EdgeWare**EL** - Eltex**EM** - EMC2**EN** - Enterasys**ER** - Ericsson**EF** - EXFO**EX** - Extreme Networks**F5** - F5 Networks**FI** - Finisar**FO** - Fortinet**FU** - Fujitsu**H3** - H3C**HI** - Hirschmann**HU** - Huawei**IB** - IBM**IF** - Infinera**IN** - Intel**IX** - Ixia**JU** - Juniper Networks**KM** - KeyMile**KY** - KyLand**LN** - Lenovo**ML** - Mellanox**ME** - Meraki (Cisco)**MT** - MikroTik**MO** - Moxa**MR** - MRV**NC** - NEC**NG** - Netgear**NK** - Nokia**NT** - Nortel**NS** - NSN**OR** - Oracle**PA** - Palo Alto Network**PL** - Planet**QC** - QCT(Quanta)**QN** - QNAP**RD** - RAD**RW** - RadWare**RC** - Raisecom**RK** - Ruckus**RU** - Ruijie Networks**SG** - Samsung**SV** - Sandvine**SC** - Silicom**SF** - SolarFlare**SW** - Sonicwall**SM** - Supermicro**SY** - Synology**TC** - Telco Systems**TP** - TP-LINK**TN** - Trendnet**UN** - Ubiquiti Networks**VX** - VeEx**WG** - WatchGuard**WS** - Waystream**WT** - Westermo**ZT** - ZTE**ZX** - Zyxel**HP** - HP**AG** - Avago**OC** - Oclaro**EU** - Emulex**TM** - Transmode**AU** - HP Aruba**XX** - Other

Warranty:

EDGE Optic's provides a limited warranty for **sixty (60)** months from Purchaser's receipt of the Equipment represented in this data sheet against defective design or workmanship.

