

Key Highlights:

- **Type:** 100G QSFP28 BIDI LR1
- **Compatibility:** Multi-Vendor MSA Compatible
- **Tx/Rx Wavelength:** 1291nm/1311nm
- **Laser:** EML
- **Modulation:** PAM4
- **Fiber Type:** Single-Mode Fiber (SMF)
- **Connectors:** Simplex LC
- **Optical Budget:** 9.8 dB
- **Max. Distance:** 20 km
- **Data Rate:** 106.25 Gbps
- **Forward Error Correction:** Integrated in DSP
- **DDM/DOM:** Supported
- **Power Consumption:** ≤ 4.5 W
- **Temperature:** Standard 0°-70°C

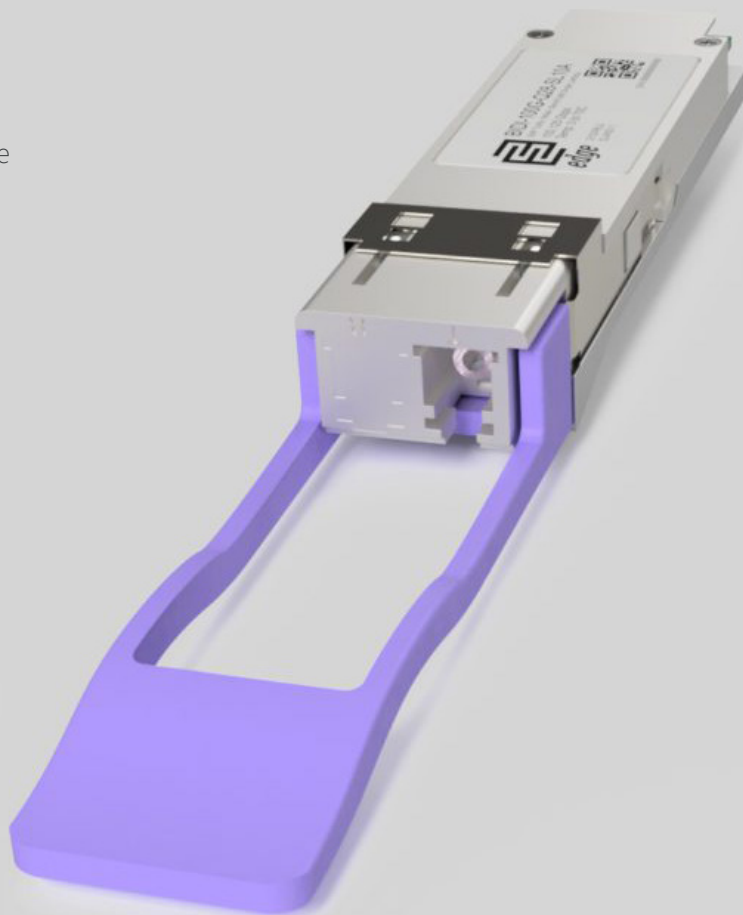

Optical Transceiver : BIDI-100G-Q28-SL20A

Product Description:

BIDI-100G-Q28-SL20A is a A side 100G QSFP28 BIDI LR1 Multi-Vendor MSA Compatible Bidirectional QSFP28 (Quad Small Form-Factor Pluggable 28) Transceiver designed for operation over Single-Mode Fiber (SMF). BIDI 100G LR1 QSFP28 has a built in BIDI 100G PAM4 (Pulse Amplitude Modulation 4-level) DSP (Digital Signal Processor) based gearbox used to convert four electrical interface lanes 4x25Gbps (CAUI-4) NRZ to one 50Gbaud (100Gbps) PAM4 signal lane. FEC (Forward Error Correction) block is also integrated in the DSP unit. This transceiver is designed for latest generation switches and routers which have PAM4 modulation support and RS (544,514) FEC technology support. 100G BIDI transceivers are designed for dense applications and provide the ability for operators and service providers to save optical fiber resources. Please note to establish A to B connection this A side BIDI-100G-Q28-SL20A module must work in pair with B side BIDI 100G LR1 module BIDI-100G-Q28-SL20B.

100G QSFP28 BIDI LR1 PAM4 A side module has a minimum guaranteed optical budget of 9.8 dB, which in most cases is enough to reach 20km over OS2 single-mode fiber with RS((544,514) FEC enabled on the host device. Without RS((544,514) FEC enabled, reach will be lower.



However, distance is just an indicative parameter calculated for comfort of identification. Eventually we calculate distance taking in account minimal optical budget and average attenuation of optical cabling in industry. 100G QSFP28 BIDI LR1 uses 1 channel 106.25 Gbps EML (External Modulation Laser) 1271 nm transmitters and 1 channel 106.25 Gbps PIN 1331 nm photodiode receivers. Module supports DDM/DOM optical diagnostics, which provide diagnostic information about the present operating conditions. 100G QSFP28 BIDI LR1 QSFP28 operates in the standard 0°-70°C temperature range and has a Single LC optical connector and 38 pins edge connector for electrical interface. 100G QSFP28 BIDI LR1 QSFP28 Side B module supports 106.25 Gbps data rate and such applications as 100G Ethernet.

100G QSFP28 BIDI LR1 QSFP28 Side B transceivers are widely used in Cisco, HP, Juniper, Huawei and other industry well known manufacturers equipment. Transceivers are CE/RoHS certified and are compliant with product safety standards. BIDI-100G-Q28-SL20A transceiver is fully compliant to Multi Source Agreement (MSA), where IEEE 802.3cd defines physical and management layer specifications CAUI-4 electrical interface, SFF-8679 defines QSFP+ 4X Hardware and Electrical Specification. Consequently, compliance to above standards guarantees that module is compatible and works with majority of networking equipment, where is not implemented special algorithm for protection against third party modules. However – we have accumulated expertise in custom-encoded firmware for BIDI-100G-Q28-SL20A in order to make these modules work in almost any brand of equipment.

Product Specification:

General parameter	Value
Media Type:	Single-Mode Fiber (SMF)
Connectors:	Single LC
TX Wavelength:	1291 nm
RX Wavelength:	1311 nm
Minimum Optical Budget:	9.8 dB
Maximum Distance:	20 km
Supported Data Rate:	106.25 Gbps
Modulation:	PAM4
Supported Applications:	100G Ethernet (106.25 Gbps)
Digital Diagnostic Monitoring (DDM):	Supported
Temperature Range:	Standard 0°-70°C
Forward Error Correction (FEC):	Integrated in DSP



Product Specification:

General parameter	Value
Storage Temperature Range:	- 40° to 85°C
Relative Humidity (Non-Condensation):	5 to 95%
Power Consumption:	≤4.5W
Power Supply Voltage Typical:	+ 3.3V
Power Supply Voltage Range:	-3.135 to 3.465V
Compliance:	IEEE 802.3cd, CAUI-4, SFF-8679, RoHS-6, CE

Transmitter Parameters:	Value
Transmitter Type:	EML TOSA
Tx Wavelength Bandwidth:	20 nm
Average Launch Power, Each Lane (Max):	-0.2 dBm
Average Launch Power, Each Lane (Min):	6.6 dBm
Extinction Ratio (Min):	3.5 dBm

Receiver Parameters:	Value
Receiver Type:	PIN ROSA
Rx Wavelength Bandwidth:	20 nm
Average Receive Power Each Lane (Min):	-10 dBm
Average Receive Power Each Lane (Max):	6.6dBm
Damage Threshold Each Lane:	7.6 dBm



Mechanical Drawing

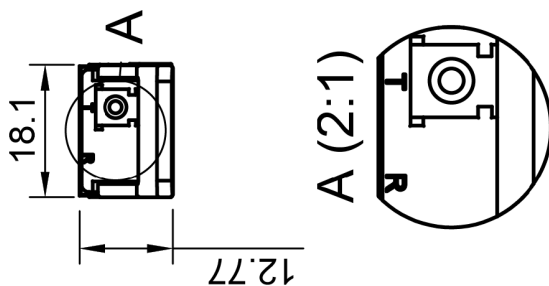
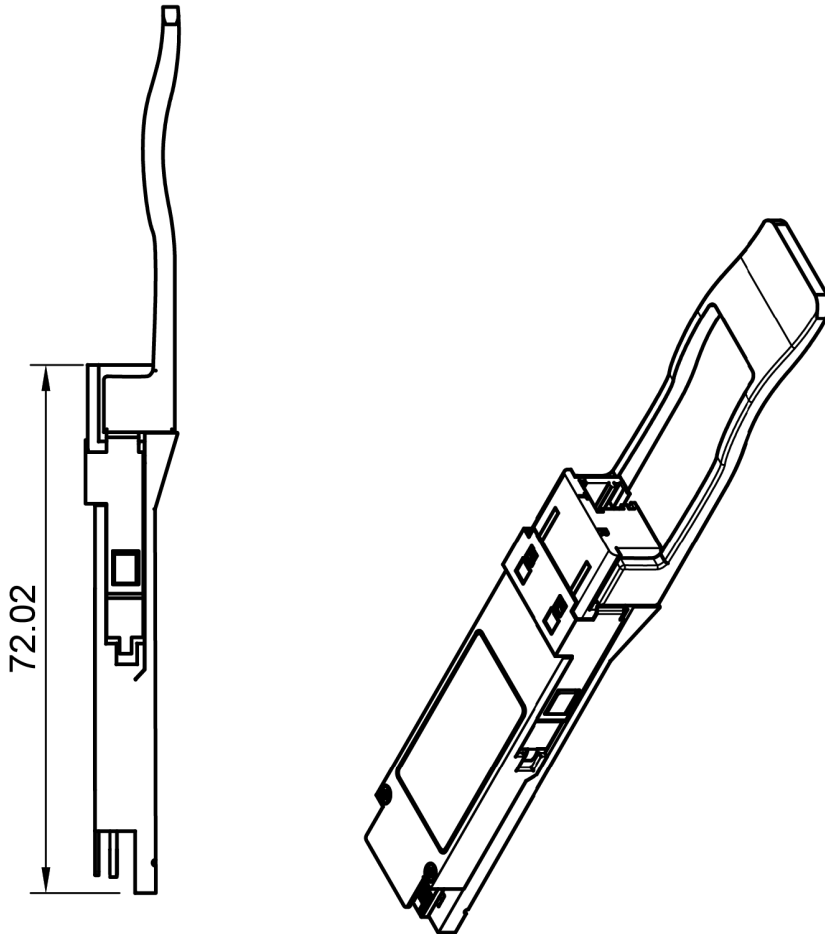

Compatibility:

EDGE Optical transceivers can be provided with custom-encoded firmware, in order to provide compatibility with more than 100 vendor brands in data and telecom communications industry:

MS - General MSA**AD** - ADVA**AE** - Advantech**AL** - Alcatel (Nokia)**AT** - Allied Telesis**AR** - Arista**AS** - Arris**AV** - Avaya**BC** - Barracuda**BR** - Broadcom**QL** - Cavium (Qlogic)**CR** - Ceragon**CP** - Checkpoint**CH** - Chelsio**CN** - Ciena**CI** - Cisco**LI** - Cisco (Linksys)**CE** - Comnet**CO** - Coriant**DH** - Dahua**DC** - DCN**DL** - Dell & Force10**DK** - D-Link**DZ** - DZS(Dasan-Zhone)**EI** - ECI**EC** - EdgeCore**EW** - EdgeWare**EL** - Eltex**EM** - EMC2**EN** - Enterasys**ER** - Ericsson**EF** - EXFO**EX** - Extreme Networks**F5** - F5 Networks**FI** - Finisar**FO** - Fortinet**FU** - Fujitsu**H3** - H3C**HI** - Hirschmann**HU** - Huawei**IB** - IBM**IF** - Infinera**IN** - Intel**IX** - Ixia**JU** - Juniper Networks**KM** - KeyMile**KY** - KyLand**LN** - Lenovo**ML** - Mellanox**ME** - Meraki (Cisco)**MT** - MikroTik**MO** - Moxa**MR** - MRV**NC** - NEC**NG** - Netgear**NK** - Nokia**NT** - Nortel**NS** - NSN**OR** - Oracle**PA** - Palo Alto Network**PL** - Planet**QC** - QCT(Quanta)**QN** - QNAP**RD** - RAD**RW** - RadWare**RC** - Raisecom**RK** - Ruckus**RU** - Ruijie Networks**SG** - Samsung**SV** - Sandvine**SC** - Silicom**SF** - SolarFlare**SW** - Sonicwall**SM** - Supermicro**SY** - Synology**TC** - Telco Systems**TP** - TP-LINK**TN** - Trendnet**UN** - Ubiquiti Networks**VX** - VeEx**WG** - WatchGuard**WS** - Waystream**WT** - Westermo**ZT** - ZTE**ZX** - Zyxel**HP** - HP**AG** - Avago**OC** - Oclaro**EU** - Emulex**TM** - Transmode**AU** - HP Aruba**XX** - Other

Warranty:

EDGE Optic's provides a limited warranty for sixty (60) months from Purchaser's receipt of the Equipment represented in this data sheet against defective design or workmanship. Warranty does not cover damage caused by improper deployment, misuse and accidents.

